

Lecture 6 – Electromagnetic Compatibility

Principles of EMC. Supply line transients. EMP and RFI. ESD. Intentional sources. Common impedance (“ground”) coupling. Capacitive coupling. Inductive coupling. Radiated coupling. Combating capacitive coupling. Combating inductive coupling. RF shielding. Grounds. Power supply distribution and decoupling. Regulatory standards.

Principles of EMC

Electromagnetic compatibility refers to the capability of two or more electrical devices to operate simultaneously without interference. A system that is electromagnetically compatible therefore satisfies the following criteria:

1. It does not cause interference with other systems.
2. It is not susceptible to emissions from other systems.
3. It does not cause interference with itself.

Additionally the system must meet regulatory requirements.

The interference that EMC refers to is known as electromagnetic interference (EMI). A common name for EMI is “noise”. Noise can be natural (e.g. lightning, solar disturbances) or human (e.g. relays, radio, radar) in origin.

One class of EMI is called radio frequency interference (RFI). RFI is propagated as an electromagnetic wave at radio frequencies (e.g. ignition coils, switch arcs).

There are always three elements involved in a noise problem: a *noise source* (line transients, relays, magnetic field etc.) a *coupling medium* (capacitance, inductance, wire, air) and a *receiver* (a circuit that is susceptible to the noise).

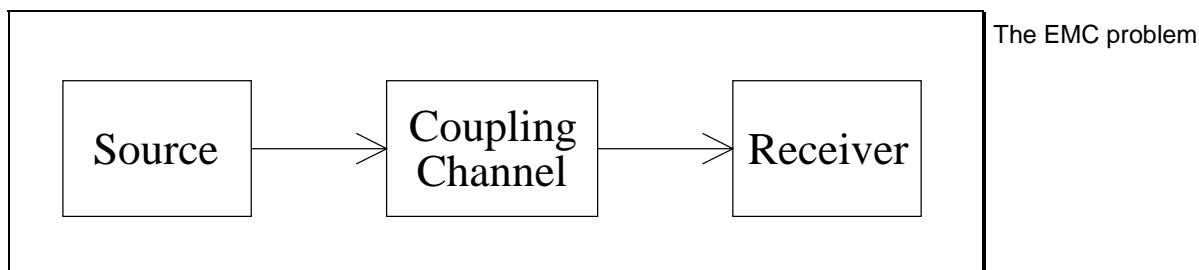

Figure 6.1 –Basic Composition of the EMC Problem

6.2

To solve a noise problem (make something electromagnetically compatible), one or more of these elements must be removed, reduced or diverted. Their role in the problem must be understood before the problem can be solved.

Types of Sources

Noise in any electronic system can originate at a large number of sources, including digital circuits, power supplies, adjacent equipment; noise sources can even include improperly connected shields and ground wires that were intended to combat noise.

Supply Line Transients

Anything that is switched will cause a transient on the supply lines. This can range from a digital circuit switching between a high and low state, or an appliance connected to a GPO.

The basic mechanism behind supply line transients is shown below:

Supply line
transients

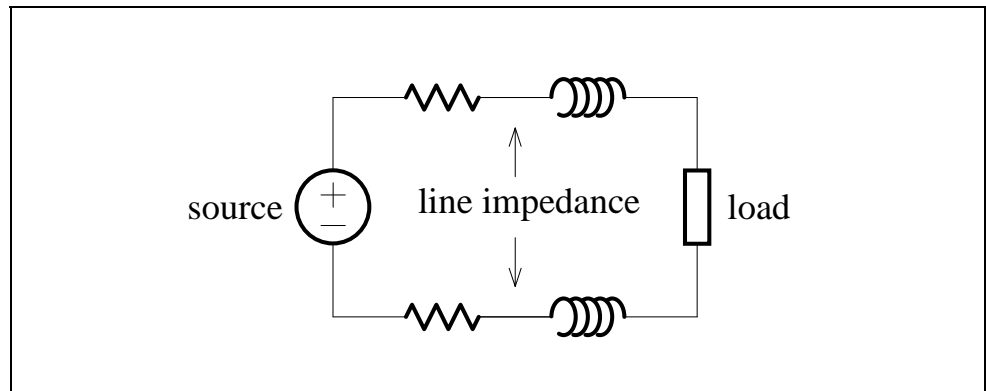

Figure 6.2 – Supply Line Transients

Any change in the load causes a transient due to the line inductance. Supply line voltage dips can cause reset conditions in microprocessors, cause distortion in analog outputs, and at the very worst, even destroy components.

EMP and RFI

Anything that produces arcs or sparks will radiate electromagnetic pulses (EMP) or radio frequency interference (RFI). Arcs and sparks occur in automotive ignition systems, electric motors, switches, static discharges, etc. In switches, the transients on the supply line will cause an opening switch to throw a spark.

ESD

Electrostatic discharge (ESD) is the spark that occurs when a person picks up a static charge (e.g. from walking on carpet) and then discharges it onto a metallic (door handle) or electronic device (CMOS chip). ESD can be very damaging to an electronic system - it can blow craters in silicon.

Intentional Sources

The power supply is an intentional signal transmitted to most electronic devices. Although it is intended to supply power, it can also couple into other signal paths.

Digital circuits are by their very nature switching circuits. They also operate at high frequencies. They therefore have supply line transient problems and emit RFI.

6.4

Coupling

There are four main ways that noise is coupled into a system. Different noise problems require different solutions. Adding a capacitor or shield will not solve every problem.

Common Impedance (“Ground”) Coupling

One of the most common methods of coupling noise is through poor design. Consider the following digital and analog system:

“Noise” can be developed by a common impedance

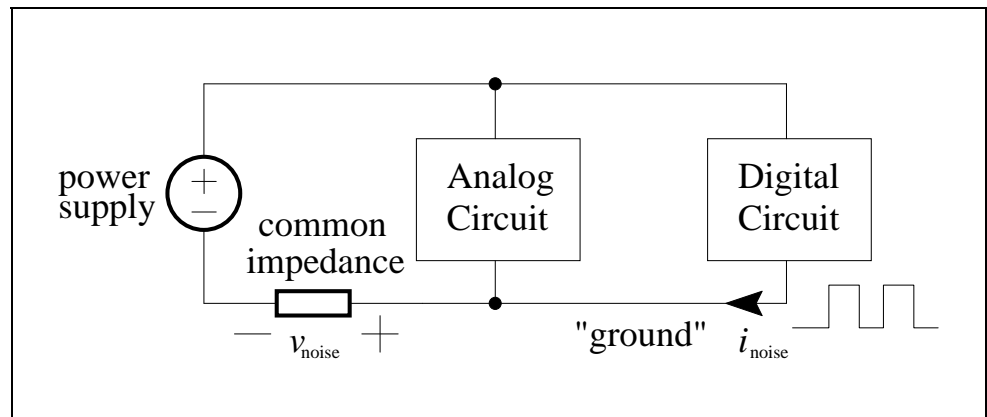
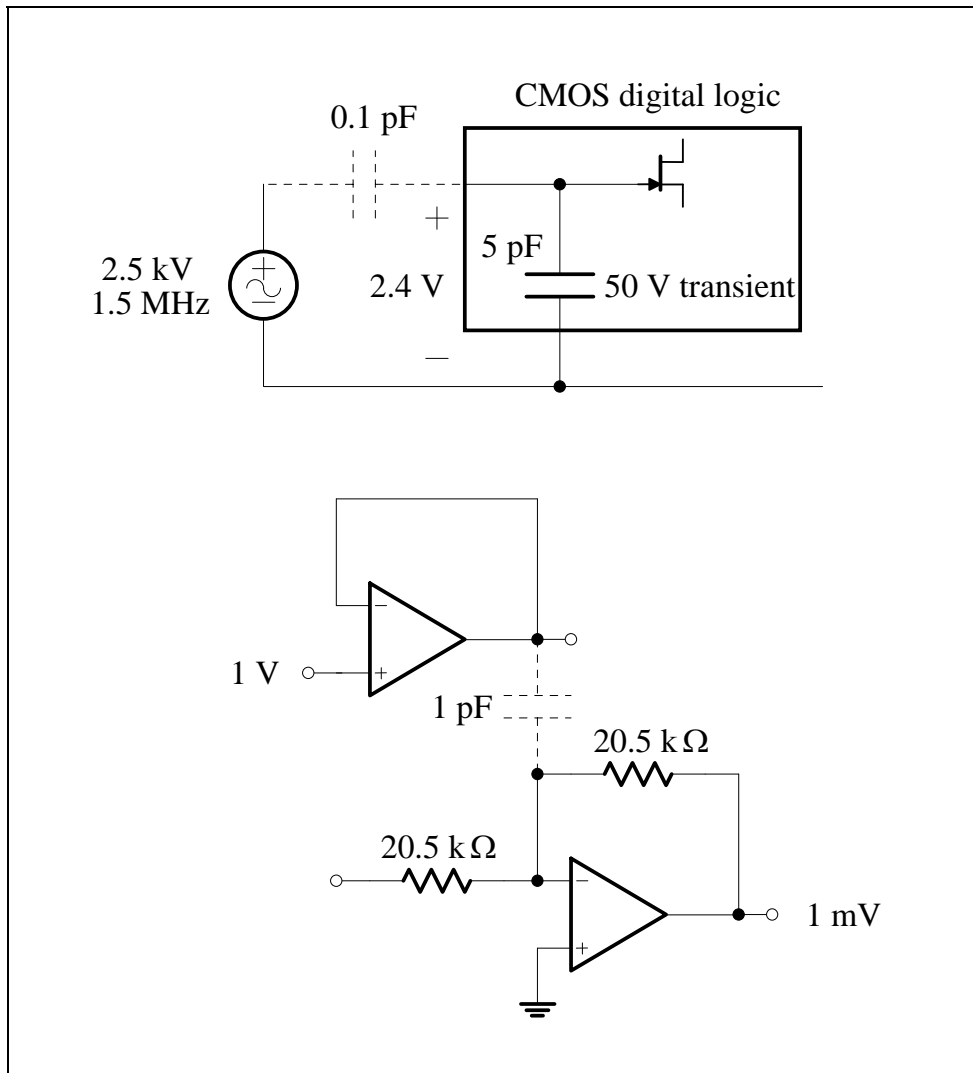

Figure 6.3 – How noise is developed by a common impedance

The “ground” point in this arrangement could be connected to op-amp non-inverting terminals (for example) and output transistors of digital logic (when they are driving low). The “ground” point has a tangible impedance to the power supply common. The noise current causes a noise voltage across the common impedance which will present itself as a noise voltage to the analog circuit.

Capacitive Coupling

Capacitive coupling involves the passage of interfering signals through mutual (or “stray”) capacitances that are never shown on the circuit diagram, but we know are there. This type of noise is often associated with fast rise and fall times or high frequencies (a capacitor is like a short circuit to high frequencies).



Stray capacitance couples “noise”

Figure 6.4 – Stray capacitance couples “noise” into other circuits

It is amazing how small mutual capacitance can cause serious problems.

6.6

Inductive Coupling

Inductive coupling is where a magnetic field from some external source links with a current loop in the victim circuit.

A current exists only in a loop. Sometimes it is difficult to determine where the current is (e.g. a ground plane), and we often ignore its path on a schematic due to the “common” and op-amp symbols. The physical geometry of the loop formed by the current is the key to understanding inductive coupling.

Any current creates a magnetic field. We know from Ampère’s Law that the field strength is dependent on the current enclosed by our path of integration in circling the current. A current loop therefore creates a magnetic field.

Inductive coupling caused by inductive loops

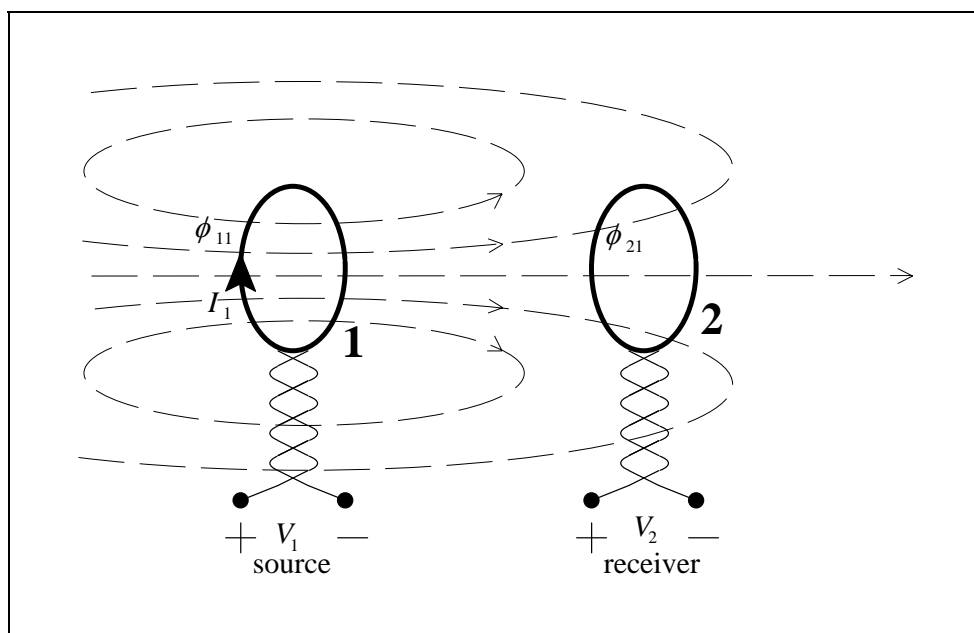

Figure 6.5 – Inductive coupling caused by current loops

If a time varying magnetic field links with a conductive loop, then Faraday’s Law applies and a voltage will be induced in the loop.

Minimising inductive coupling does not necessarily involve magnetic materials. If two conductors, each carrying a current I in opposite directions, are in close proximity then the external magnetic field tends to cancel.

Radiated Coupling

A time-varying electric field generates a time-varying magnetic field and vice versa. Far from the source of a time-varying EM field, the ratio of the amplitudes of the electric and magnetic fields is always 377Ω . Close to the source of the fields, however, this ratio can be quite different, and dependent on the nature of the source. The region in space where the ratio is near 377Ω is called the far field, and the region where the ratio is significantly different from 377Ω is called the near field.

The near field goes out about $1/6$ of a wavelength from the source. At 1 MHz this is about 50 m and at 10 MHz it's about 5 m. This means that if an EMI source is in the same room with the victim circuit, then it's most likely to be a near field problem. The reason this matters is that in the near field an RF interference problem could be almost entirely due to E -field coupling or H -field coupling, and this influences the way in which we combat this type of noise.

In the near field of a whip antenna, the E/H ratio is higher than 377Ω , which means it's mainly an E -field generator. A wire-wrap post or a test point terminal can be a whip antenna. Interference from a whip antenna would be by electric field coupling, which is basically capacitive coupling.

In the near field of a loop antenna, the E/H ratio is lower than 377Ω , which means it's mainly an H -field generator. Any current loop is a loop antenna. Interference from a loop antenna would be by magnetic field coupling, which is basically the same as inductive coupling.

Even so, in the near field and far field, the fact that the EMI is being radiated means we have to treat this type of coupling differently.

6.8

Combating EMI

There is a whole range of techniques that help combat EMI. They range from minimising the generation of noise voltages, reducing the coupling, and making a graceful recovery after being subjected to an electromagnetic disturbance.

Some techniques, like grounding and shielding, attack the EMI problem from many sides. *Consideration of EMC at the design stage, such as PCB layout, can prevent many noise problems from ever occurring.*

Combating Capacitive Coupling

Reducing Mutual (Stray) Capacitance on a PCB

- Lay tracks as far apart as possible on a PCB (separate high- and low-level signals).

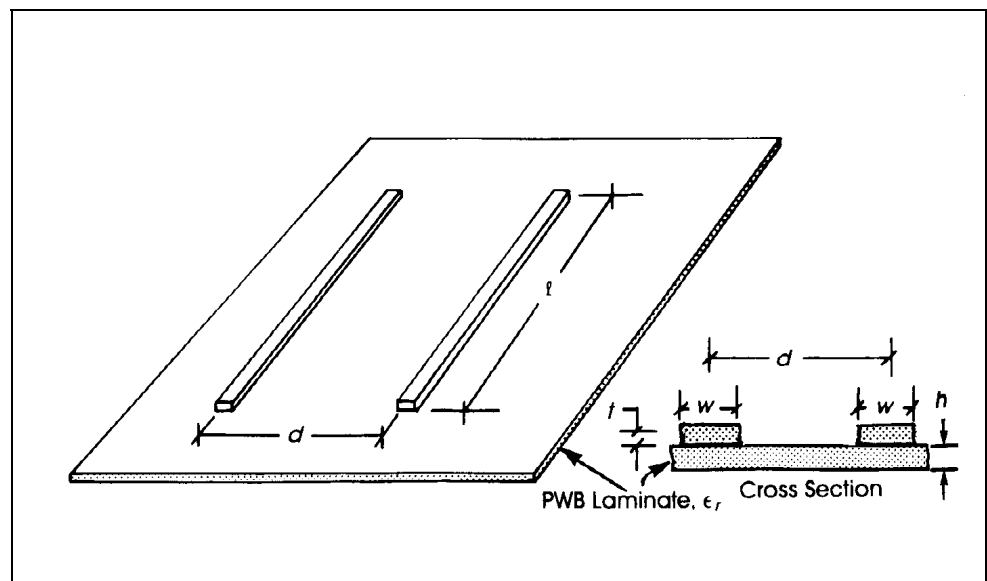

Figure 6.6 – Separate tracks to reduce capacitance

- Use a ground plane.

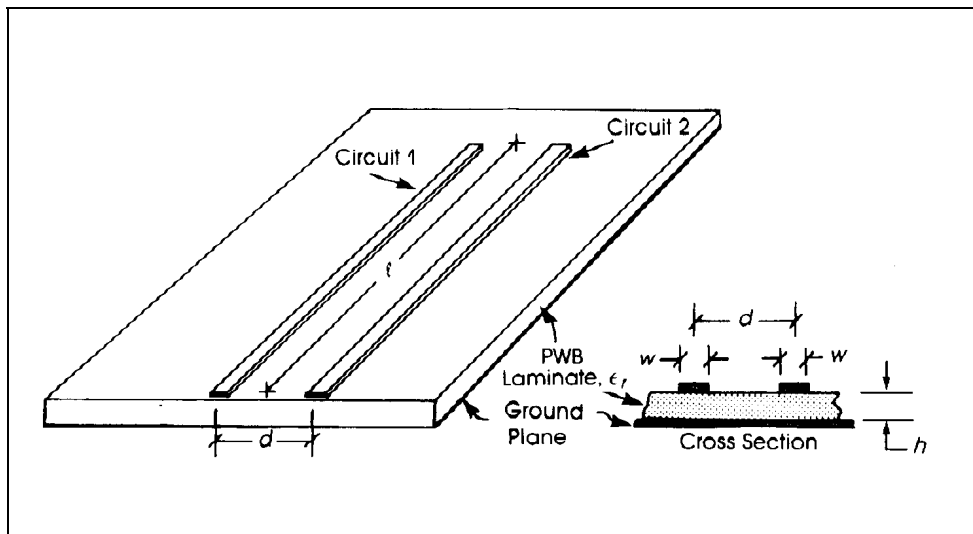

Figure 6.7 – Use a ground plane to minimise mutual capacitance

Properly Implemented Shields

- Connect shields to the common at the source.

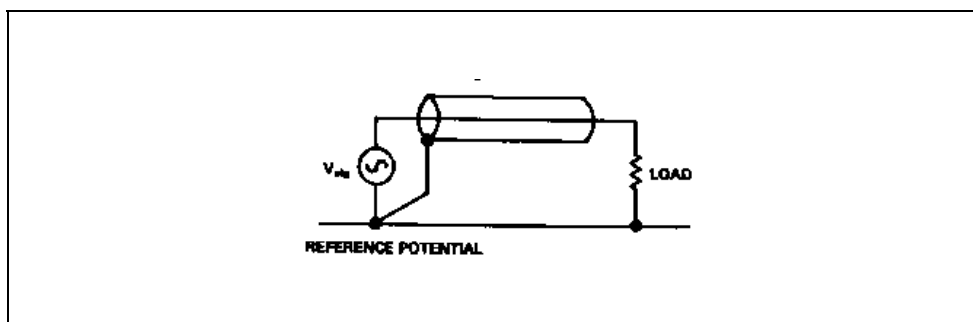

Figure 6.8 – Grounding a cable shield

- Don't connect both ends of the shield to "ground".

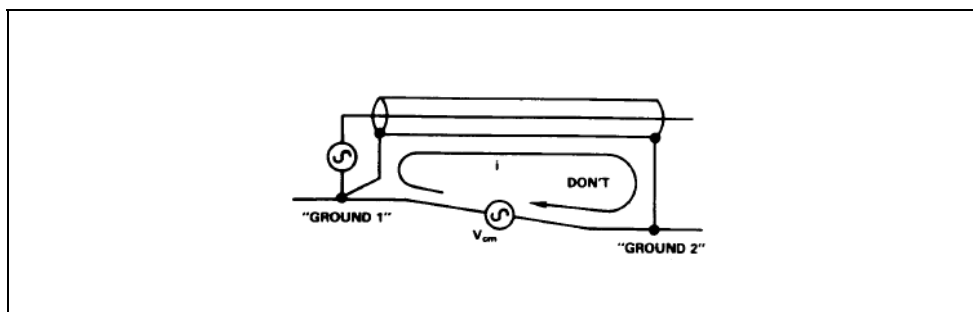

Figure 6.9 – Don't connect the shield to ground at more than one point

6.10

- Don't allow shield current to exist (conflicts with combating inductive coupling).

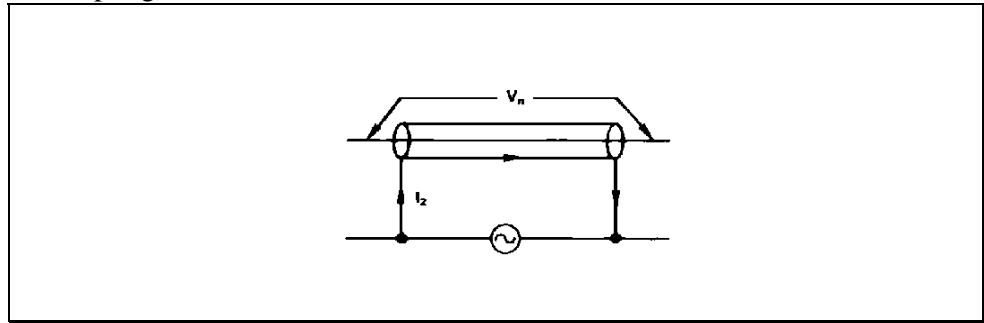

Figure 6.10 – Magnetic pickup from current through a cable shield

- Don't allow the shield to be at a voltage with respect to the reference potential.

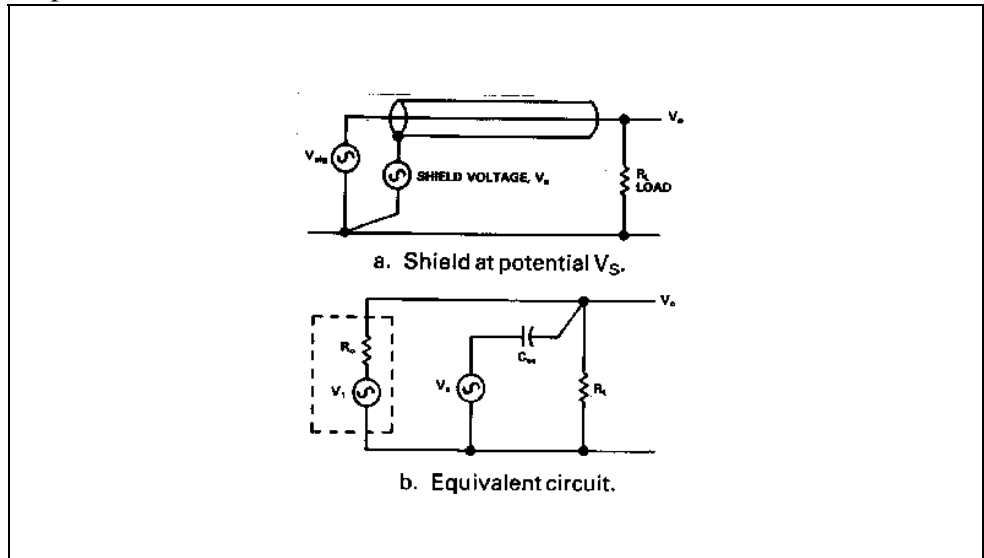

Figure 6.11 – Don't allow the shield to be at a voltage with respect to the reference potential

- Know by careful study how the noise current that has been captured by the shield returns to “ground”.

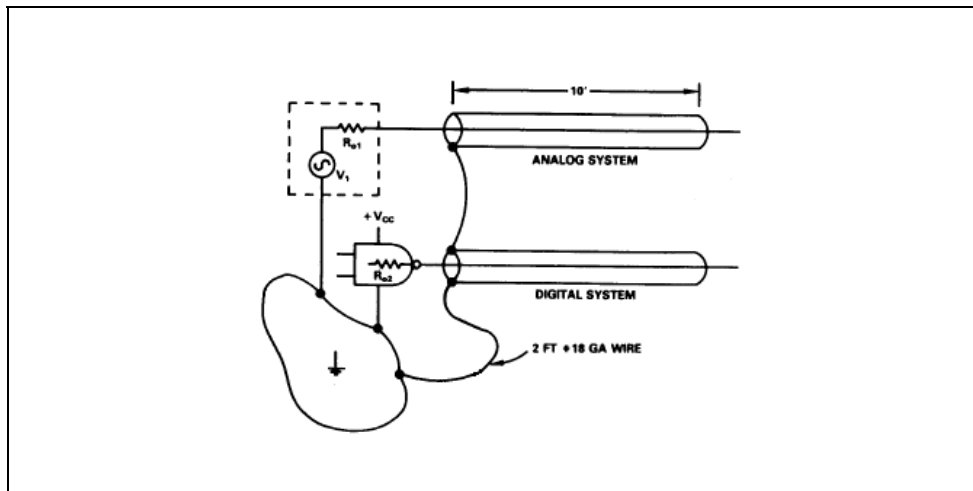

Figure 6.12 – A situation that generates transient shield voltages

- Use a Faraday shield to isolate whole circuits.

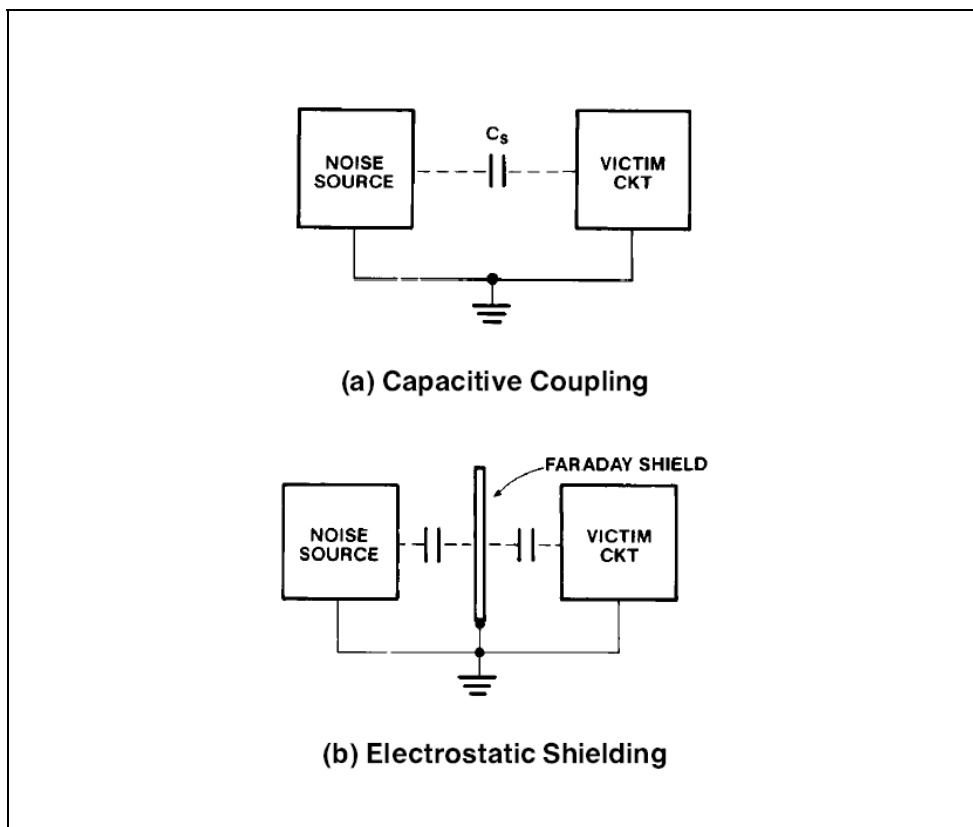

Figure 6.13 – Use of Faraday shield

6.12

Combating Inductive Coupling

Reducing Mutual Inductance on a PCB

- Minimise current loop areas.
- Use a ground plane (or gridded-ground).

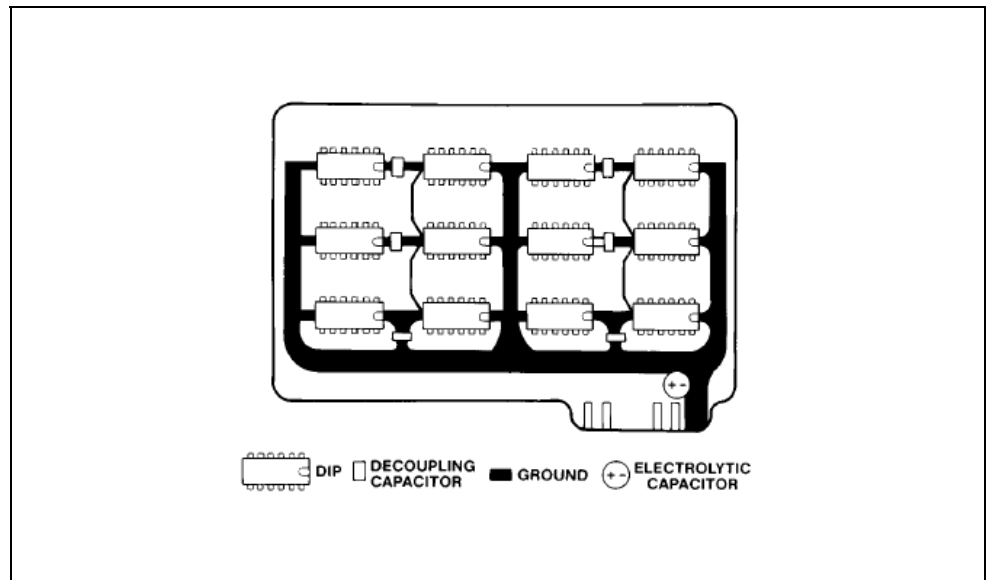

Figure 6.14 – PCB with gridded ground

- Orient susceptible loops at right angles to the magnetic field, if possible.

Shields

- Use coaxial cable.

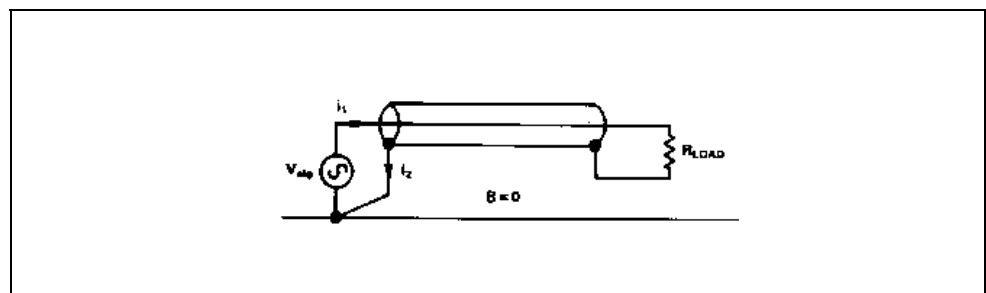

Figure 6.15 – Use a shield for return current to a noisy source

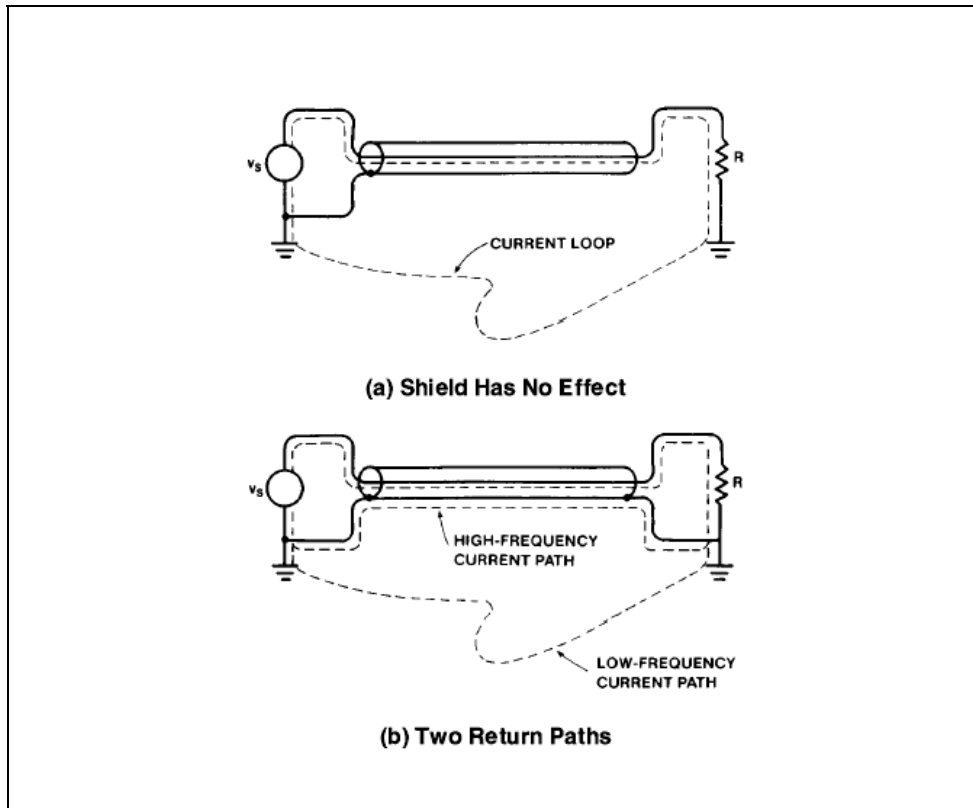

Figure 6.16 – Use of coaxial cable

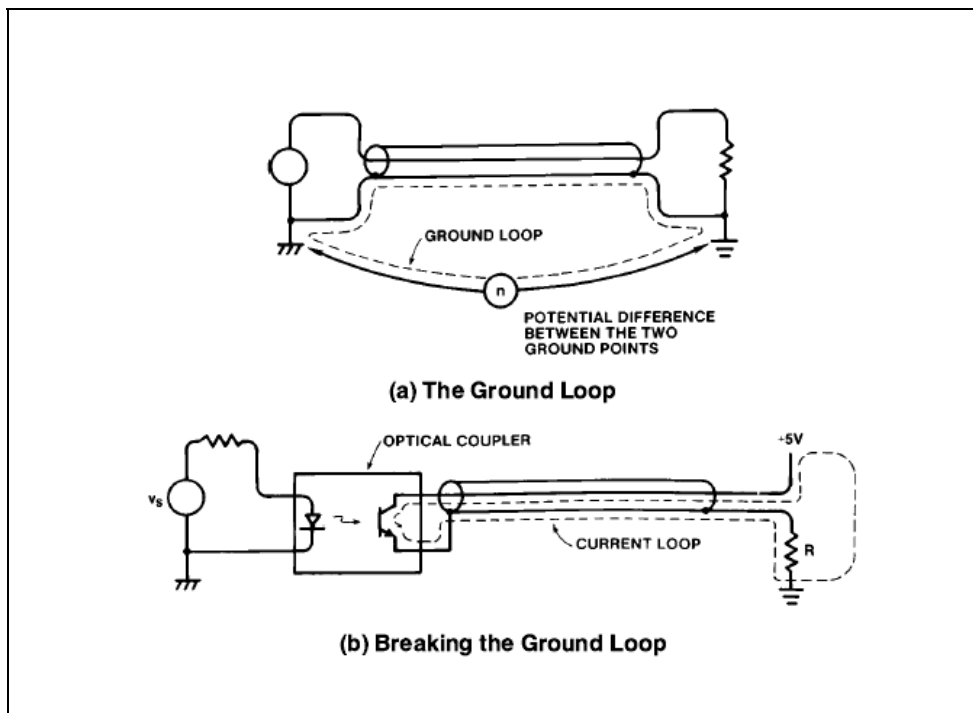

Figure 6.17 – Use of optical coupler

6.14

- Use a twisted pair of wires.

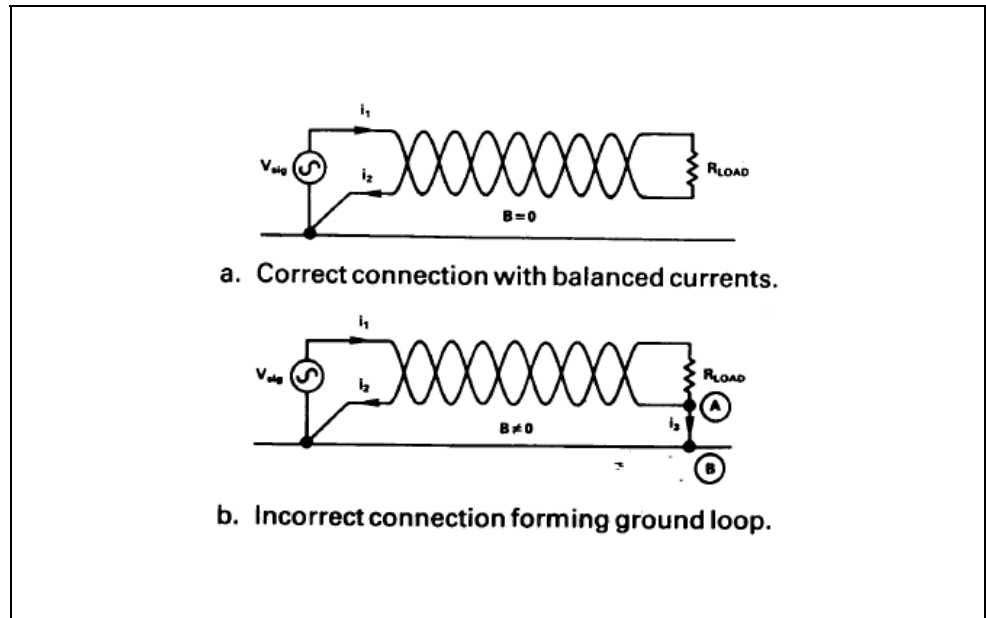

Figure 6.18 – Connections of a twisted pair

- Use an appropriate shielding material for the frequency and field strength.

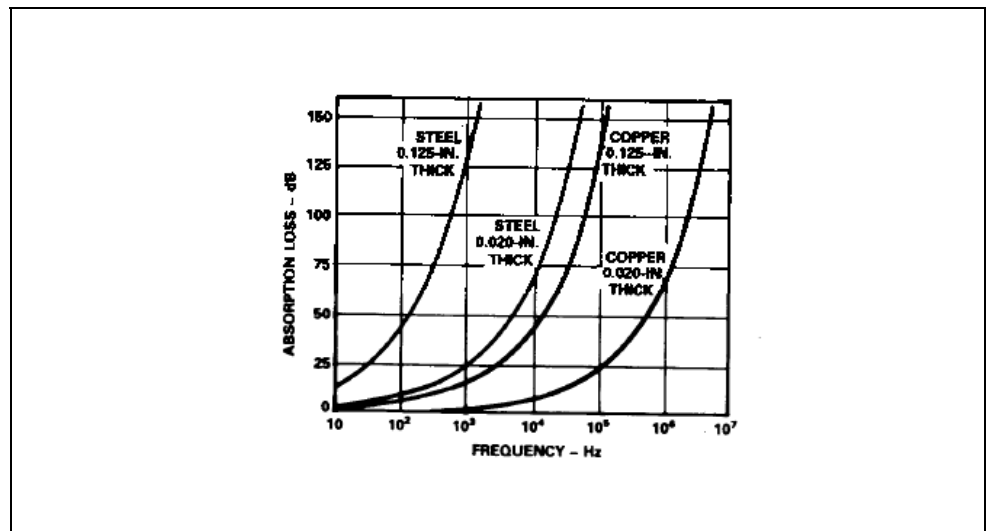

Figure 6.19 – Absorption loss vs. frequency for two thicknesses of copper and steel

- Use steel or mumetal at power frequencies.

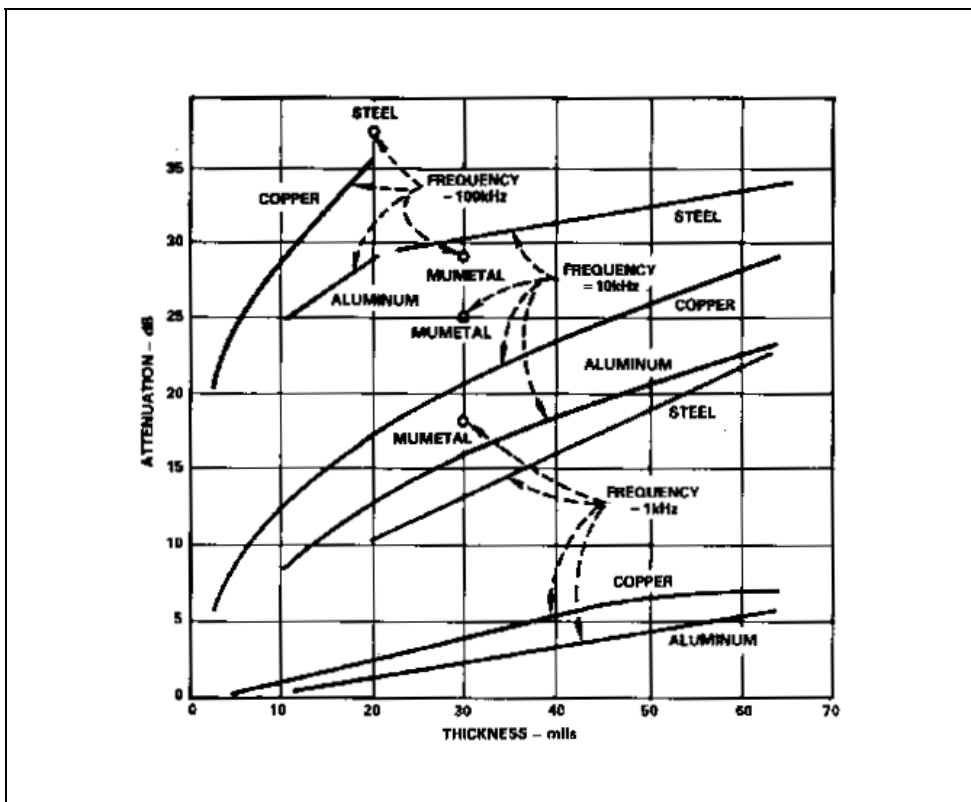

Figure 6.20 – Absorption loss vs. frequency for two thicknesses of copper

RF Shielding

- Use copper or aluminium for E -field shielding (rare).

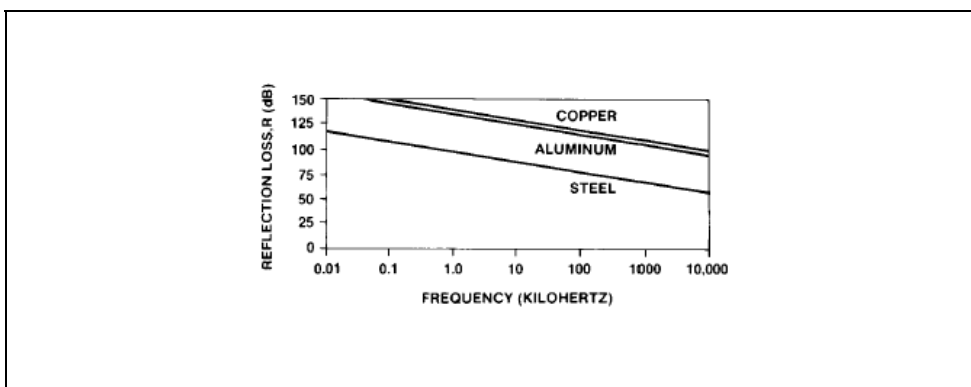

Figure 6.21 – E-field shielding

6.16

- Use steel for *H*-field and far field shielding (common).

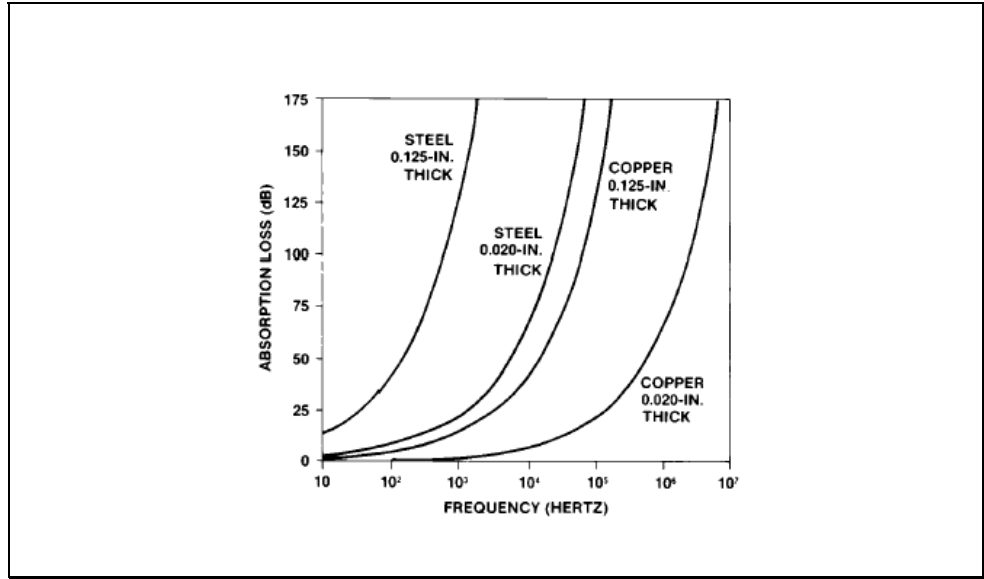

Figure 6.22 – H-field shielding

- Use steel if in doubt.

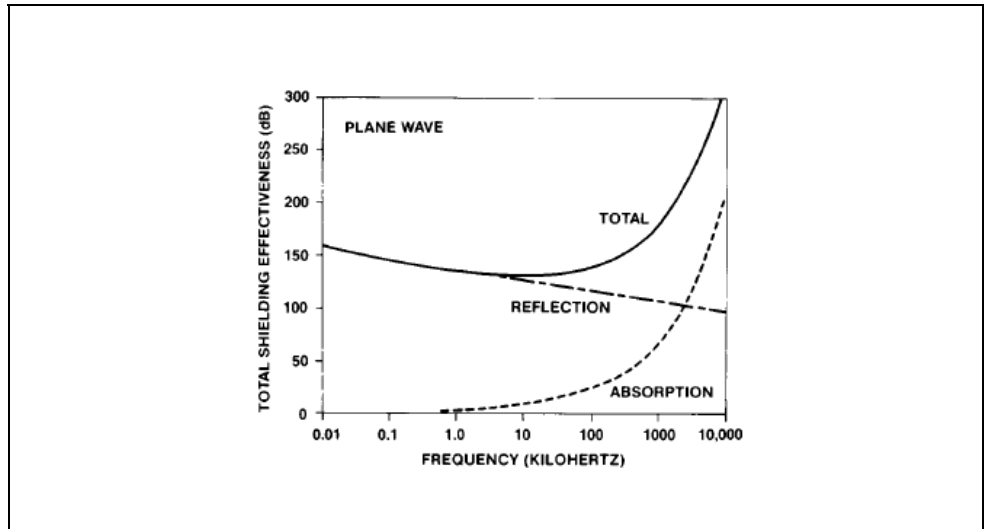

Figure 6.23 – E- and H-field shielding

- Avoid seams, joints and large holes in the shield.

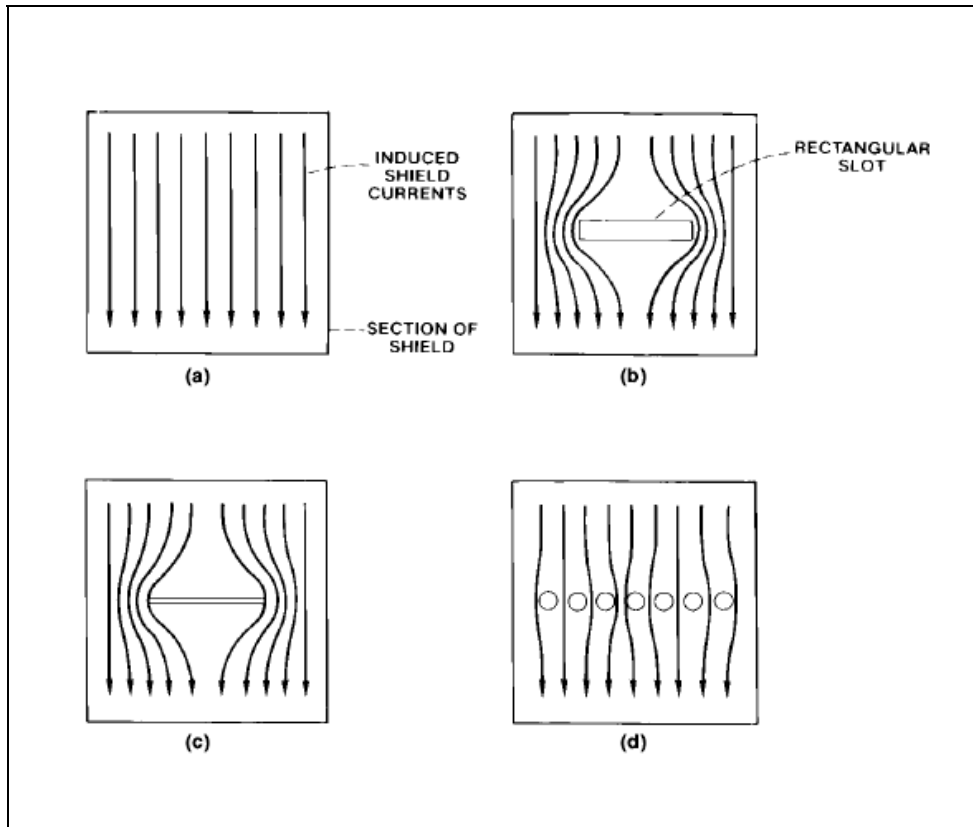

Figure 6.24 – Effect of shield discontinuity on magnetically induced shield current

6.18

Grounds

- Use a combination of serial and parallel ground-wiring.

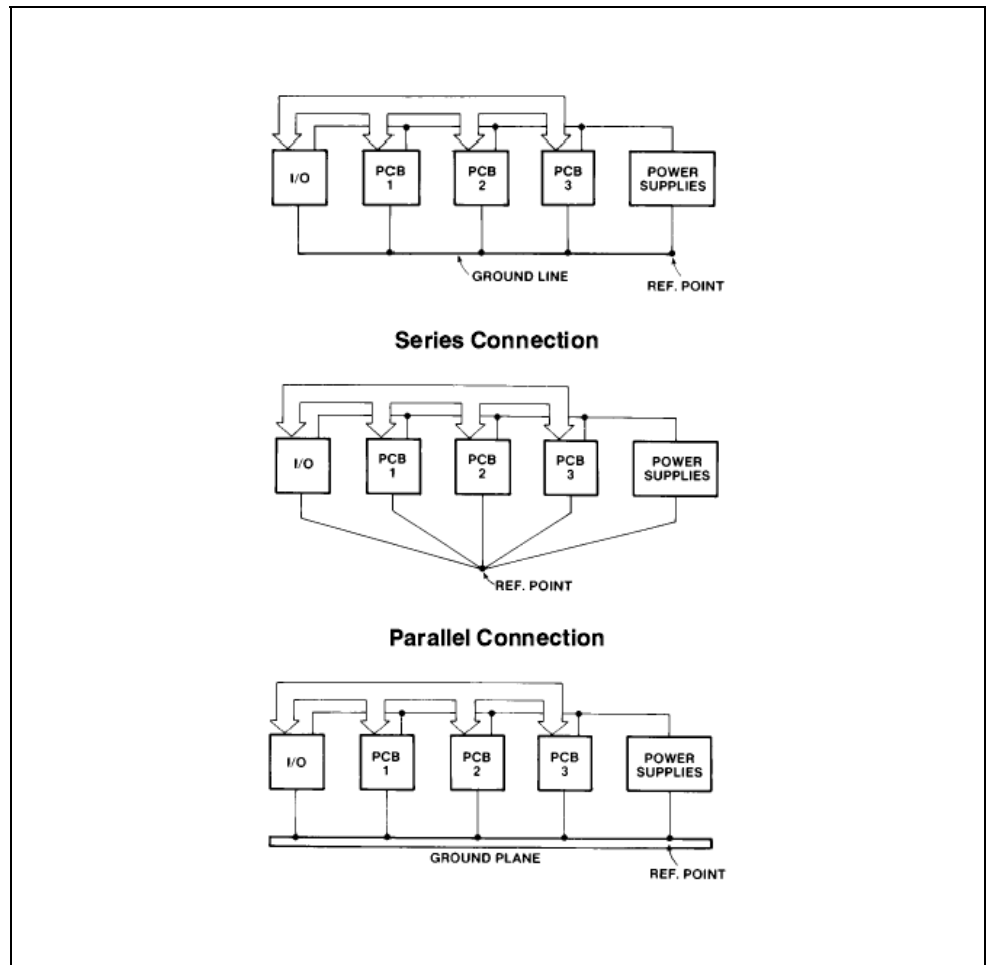

Figure 6.25 – Three ways to wire the grounds

- Separate digital grounds and analog grounds.

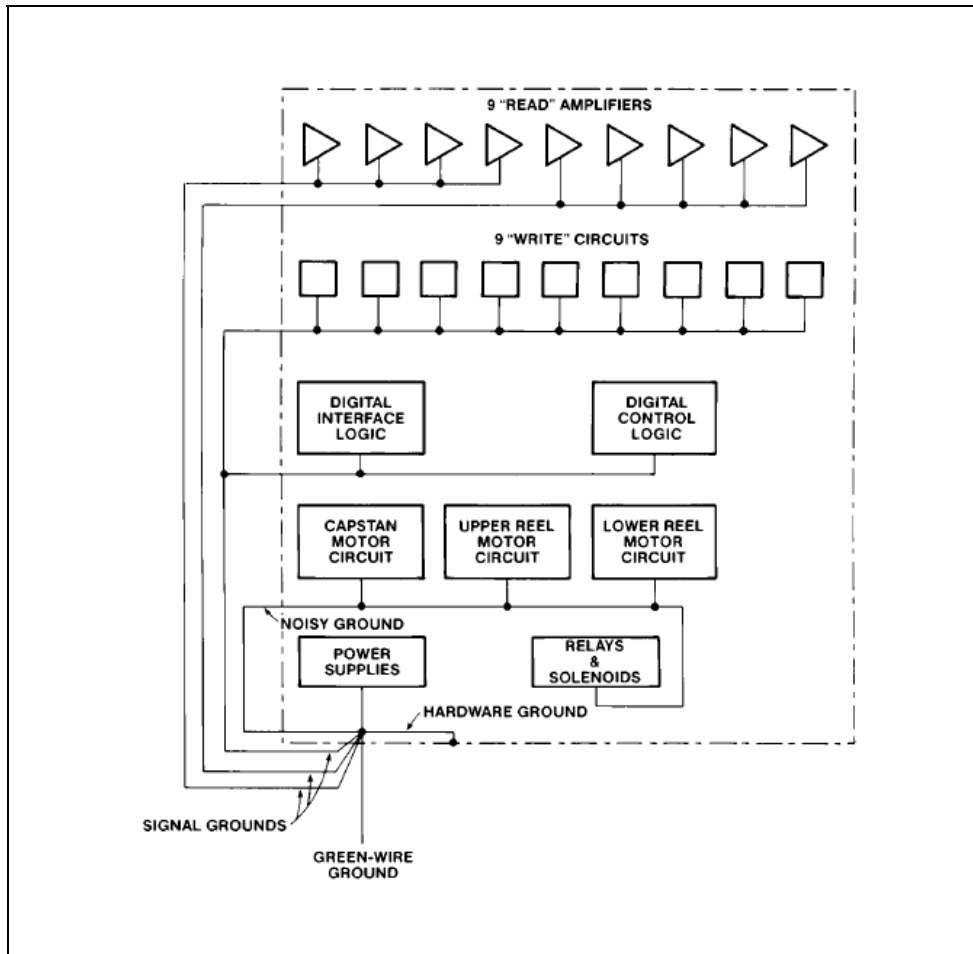

Figure 6.26 – Ground systems in a 9-track digital recorder

- Separate power grounds and signal grounds.

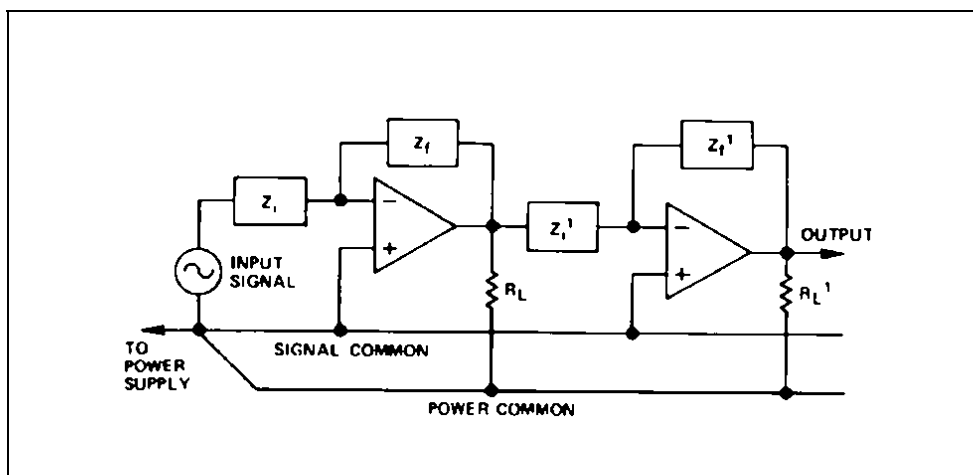

Figure 6.27 – Minimizing common impedance coupling

6.20

- Use a ground plane.

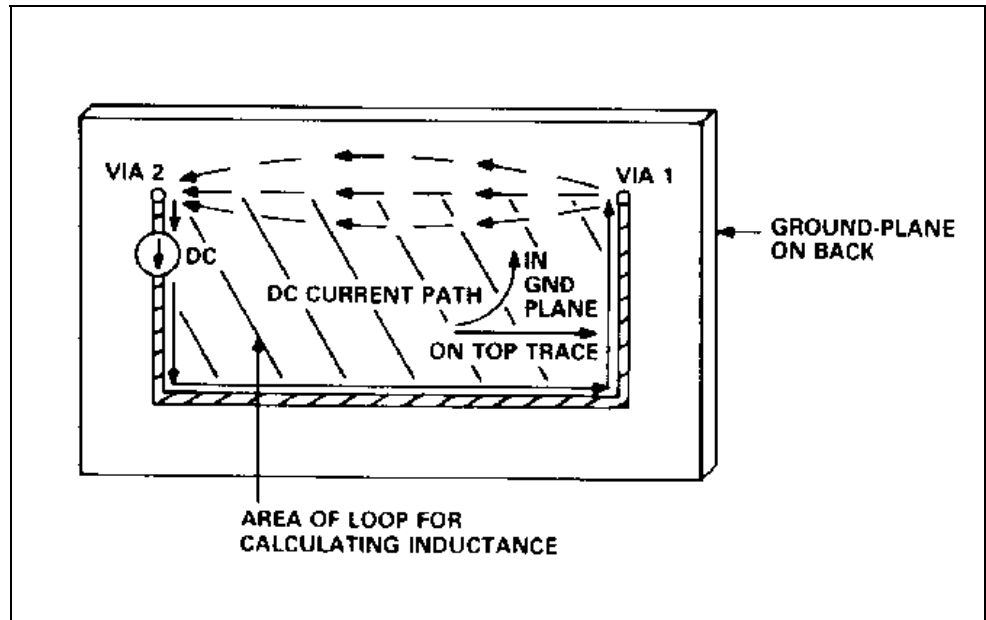

Figure 6.28 – DC current path

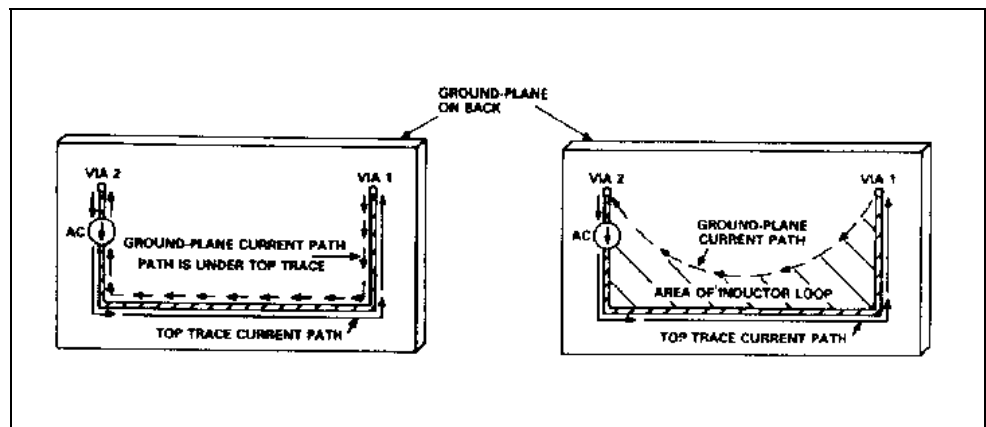

Figure 6.29 – AC current path without (left) and with (right) resistance in ground plane

- Connect signal grounds to AC power ground for safety.

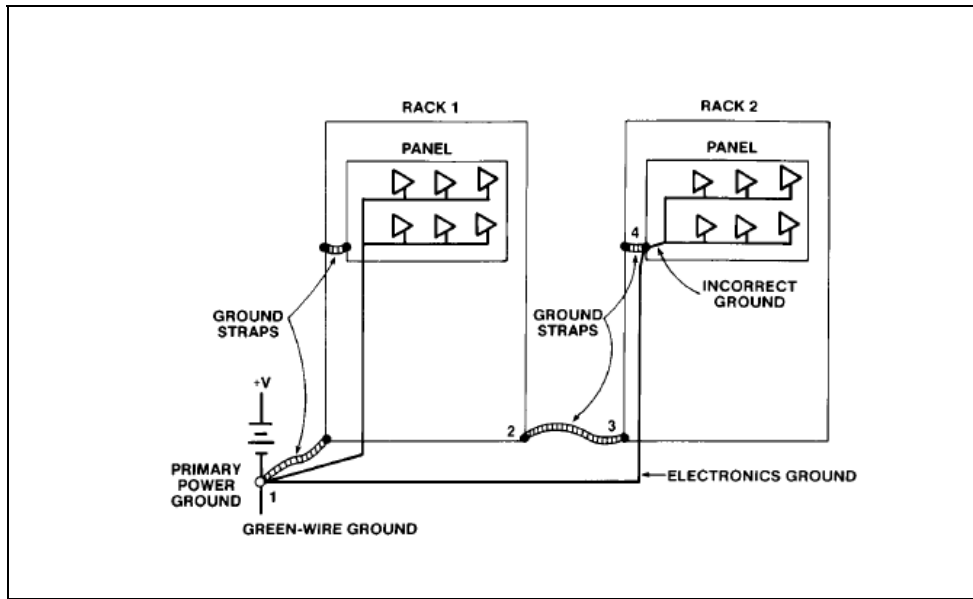

Figure 6.30 – Electronic circuits mounted in equipment racks should have separate ground connections. Rack 1 shows correct grounding, Rack 2 shows incorrect grounding

Power Supply Distribution and Decoupling

- Use decoupling capacitors on all I.C.s.

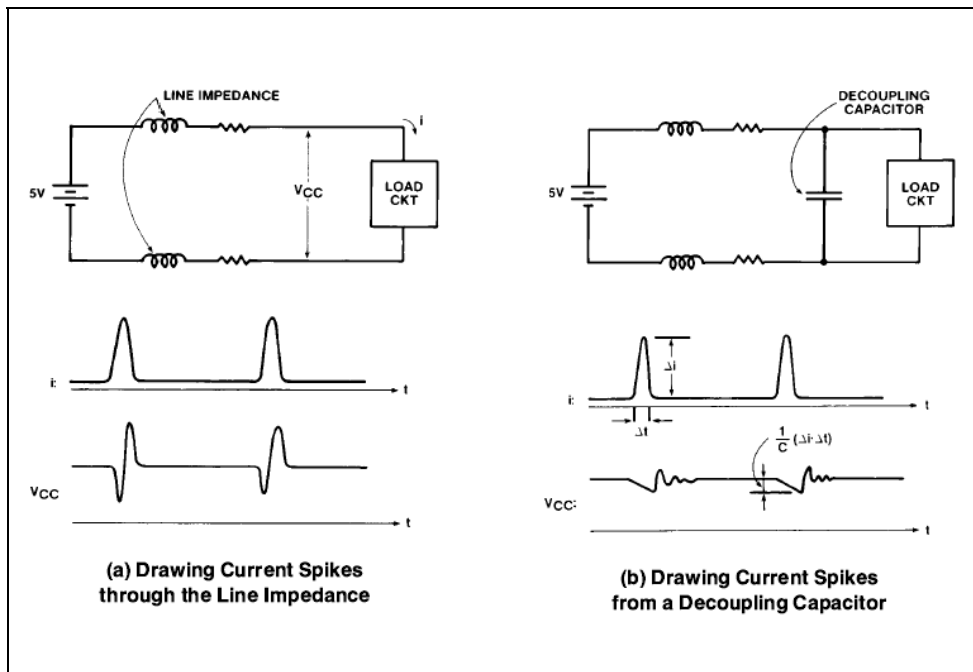

Figure 6.31 – What a decoupling capacitor does

6.22

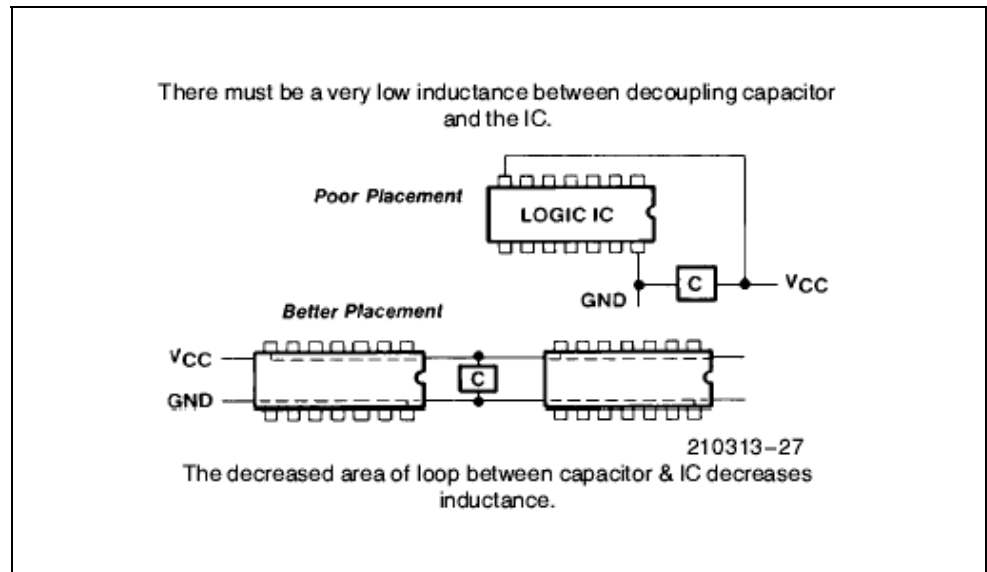

Figure 6.32 – Placement of decoupling capacitors

- Use a large decoupling capacitor (usually electrolytic) for the whole PCB.
- Use regulators.
- Use transient suppressors.

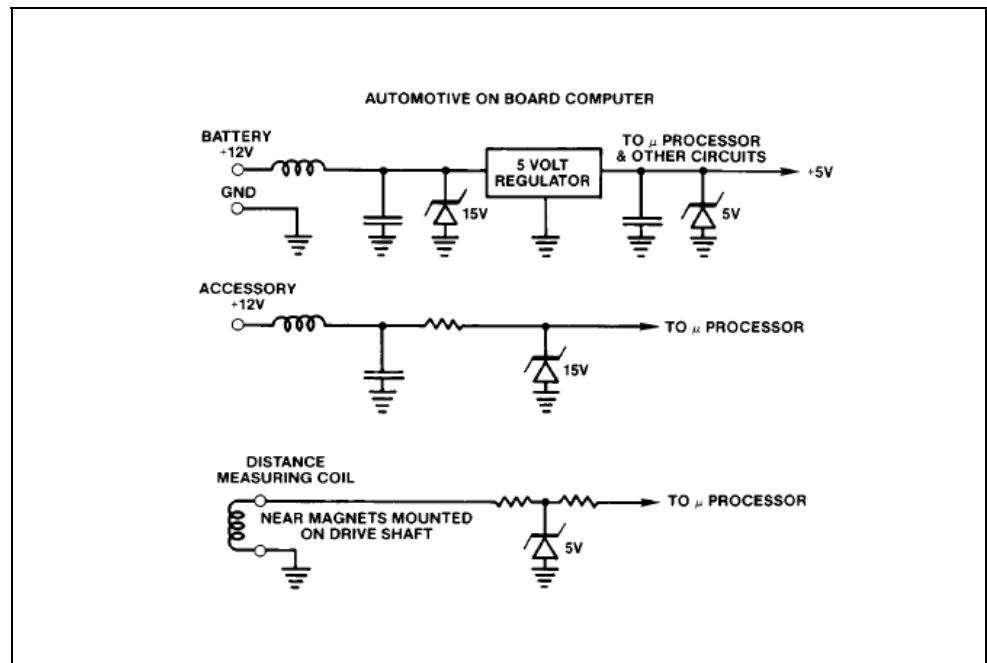

Figure 6.33 – Use of transient suppressors in automotive applications

- Minimise loop areas to decoupling capacitors.

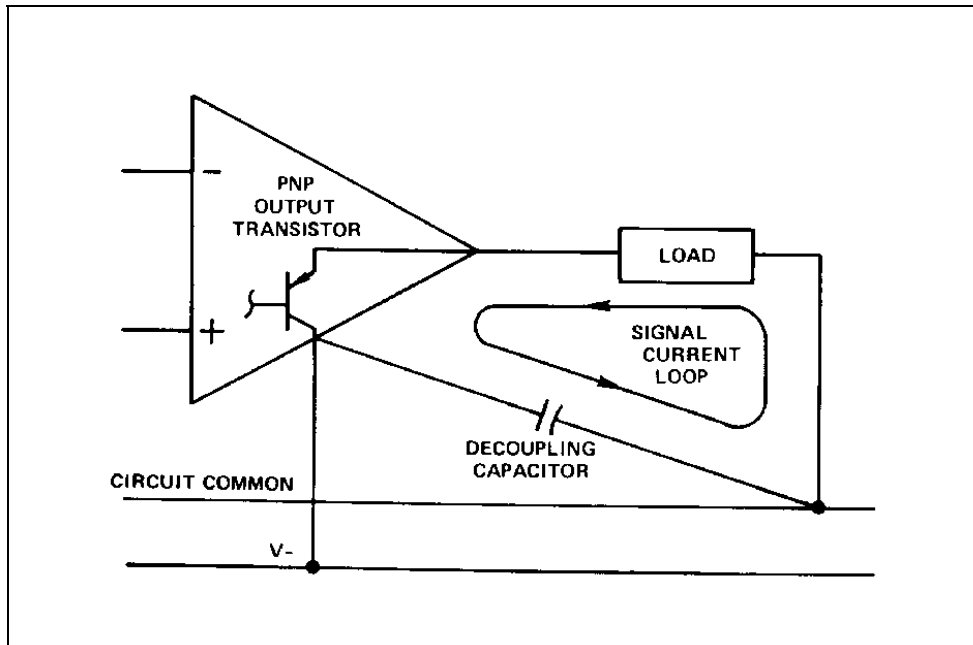

Figure 6.34 – Decoupling of negative supply for a grounded load

- Use large tracks for power distribution on PCBs (minimise impedance).

6.24

Regulatory Standards

In the early 1990s, countries in Europe started taking the issue of electromagnetic compatibility seriously as the number of interfering and susceptible devices increased, especially in the automotive and medical environments. The European Union (EU) established numerous standards in the late 1990s which were later adopted by the International Electrotechnical Commission (IEC). These IEC standards form the basis of standards in countries all around the world. The EU enforced EMC compatibility in 1997 by passing laws barring products from the marketplace that were not compliant with the standards. Products that are compliant are labelled with a “CE marking”.

The Australian Communications and Media Authority (ACMA) provides regulations that must be met in order to supply products to the Australian and New Zealand market. Products that are EMC compliant have a “C-tick” label placed on them which allow them to be sold in the Australian and New Zealand market. Products intended for the telecommunications market must meet further regulatory requirements and are labelled with an “A-tick”.

In the United States of America, EMC compliance is handled by the Federal Communications Commission’s “Part 15 – Radio Frequency Devices”. Products that conform to the guidelines receive an FCC marking.

EMC compliance markings for Western markets are shown below:

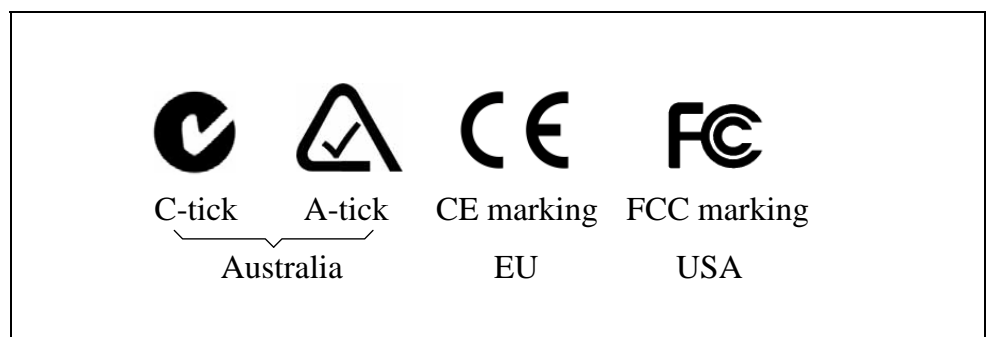

Figure 6.35 – EMC compliance markings

The most common standards which are used for compliance testing are:

- EN 55024:1998 *Information technology equipment – Immunity characteristics* – Limits and methods of measurement
- EN 61000-3-2:2000 *Electromagnetic compatibility (EMC) – Part 3-2: Limits* – Limits for harmonic current emissions (equipment input current up to and including 16 A per phase)
- EN 61000-3-3:1995 *Electromagnetic compatibility (EMC) – Part 3-3: Limits* – Limitation of voltage changes, voltage fluctuations and flicker in public low-voltage supply systems, for equipment with rated current ≤ 16 A per phase and not subject to conditional connection
- FCC Part 15 – *Radio Frequency Devices*
- AS/NZS CISPR 22:2006 : *Information technology equipment - Radio disturbance characteristics* – Limits and methods of measurement
- AS/NZS 61000.6.1:2006 : *Electromagnetic compatibility (EMC) – Generic standards* – Immunity for residential, commercial and light-industrial environments

Products that do not comply with local regulations are *illegal* and cannot be placed in that market.

In Australia, if a product's compliance is called into question, the ACMA will carry out investigations. For wilful violations, penalties may apply to both individuals and companies. A primary offence for the supply of a non-standard device may result in the seizure and forfeiture of stock and up to \$160,000 criminal penalties. Imprisonment is also possible under the Crimes Act and offences are also committed for breaches of the C-Tick labelling provisions under Trade Mark and Copyright regulations. Similarly harsh penalties are applicable in most other countries that have EMC regulations.

6.26

References

Australian Communications and Media Authority,

<http://www.acma.gov.au/WEB/HOME/PAGE//pc=HOME>

Brokaw, Paul & Barrow, Jeff: “Grounding for Low- and High-Frequency Circuits - Know Your Ground and Signal Paths for Effective Designs, Current Flow Seeks Path of Least Impedance - Not Just Resistance”, *The Best of Analog Dialogue*, Analog Devices, Inc., 1991, pp 193-195.

Rich, Alan: “Understanding Interference-Type Noise - How to Deal with Noise without Black Magic - There Are Rational Explanations for - and Solutions to - Noise Problems”, *The Best of Analog Dialogue*, Analog Devices, Inc., 1991, pp 120-123.

Rich, Alan: “Shielding and Guarding - How to Exclude Interference-Type Noise, What to Do and Why to Do It - A Rational Approach”, *The Best of Analog Dialogue*, Analog Devices, Inc., 1991, pp 124-129.

Walker, Charles S.: *Capacitance, Inductance and Crosstalk Analysis*, Artech House, Boston, 1990.

Williams, T: *EMC for Product Designers 2nd Ed.*, Reed Educational and Professional Publishing Ltd., 1996.

Williamson, Tom: “Designing Microcontroller Systems for Electrically Noisy Environments”, *Embedded Controller Applications Handbook*, Intel Corporation, 1988.

<http://developer.intel.com/design/mcs96/applnots/210313.htm>